

## Handout 1

# A guide to preventing falls

Falling is a very serious health problem for seniors.

## Did you know?

- ◆ Across Canada, one in three seniors fall each year.<sup>1</sup>
- ◆ Ninety per cent (90%) of broken hips in seniors are a result of a fall.<sup>2</sup>
- ◆ By the age of 75, falls are the major cause of fatal injuries.<sup>3</sup>
- ◆ Forty per cent (40%) of admissions to nursing homes are related to falls.<sup>4</sup>
- ◆ Direct costs associated with falls are \$2.4 billion dollars.<sup>5</sup>

## Why do seniors fall?

Usually falls have more than one cause. For example, someone who slips or falls on a slippery floor may have weak leg muscles and be experiencing dizziness as a side effect of medication. This booklet reviews the causes of falls and recommends changes you can make in the following areas to prevent falls:

- ◆ Exercise
- ◆ Medication
- ◆ Assistive devices
- ◆ Environmental hazards (surroundings inside and outside your home)

<sup>1</sup> Tinetti, M.E., Speechley, M. (1989). Prevention of falls among the elderly. *New England Journal of Medicine*.

<sup>2</sup> Zuckerman, J.D. (1996). Hip fracture. *New England Journal of Medicine*, 334(23), 1519-1525.

<sup>3</sup> Les traumatismes dûs aux chutes. Les chutes chez les personnes âgées, 1991.

<sup>4</sup> Geriatric Consultant, 1983.

<sup>5</sup> The Hygeia Group. (1998). The economic burden of unintentional injury in Canada. Smartrisk.



## Exercise

Inactivity, chronic disabilities such as diabetes and arthritis, abnormal blood pressure and changes associated with normal aging can lead to gait and balance disorders and loss of mobility. Regular physical activity and exercise will increase muscle strength, improve coordination and help to prevent falls.

### Stay active to prevent falls:

- ◆ Flexibility activities, e.g. Tai Chi or gardening.
- ◆ Strength and balance activities, e.g. climbing stairs, or wall push-ups.

For more information see Handout 4 – Canada’s Physical Activity Guide to Healthy Active Living for Older Adults.

### What to do:

- ◆ Talk to your doctor before you start an exercise program.
- ◆ Tell your doctor about changes in balance.
- ◆ Avoid sudden changes in position.
- ◆ Never bend down all the way to the floor, and avoid getting up quickly after stooping.
- ◆ Make sure the exercises you choose are beneficial for you.
- ◆ Look at the resource list on the last page for program ideas.
- ◆ Make your activities as enjoyable as possible. Find a buddy!
- ◆ Find out about exercise/activity programs for seniors in your area.

## Medication

### Seniors are more at risk of falls if they take:

- ◆ Four or more medications daily.
- ◆ Medications to help them sleep or calm their nerves (sedatives).\*

**Warning:** Side effects of medications such as dizziness or feeling light-headed can also increase your risk of falling. Some medications react with others and this may increase side effects.

\* American Journal of Epidemiology, 1990

## What to do:

- ◆ Review all your medications with your doctor every six months.
- ◆ Ask your doctor or pharmacist about the side effects of the medication you take.
- ◆ Take medications correctly as indicated. Use a medication box.
- ◆ Tell your doctor if your medication makes you dizzy or light-headed.
- ◆ Avoid taking alcohol with medications.
- ◆ Talk to your pharmacist before you take non-prescription, over-the-counter and herbal remedies.
- ◆ Never take someone else's medication.
- ◆ Instead of taking medication to help you sleep, consider alternatives such as listening to soft music, reading or relaxation exercises.
- ◆ Talk to your doctor if insomnia persists.
- ◆ Keep a list or record of all your medications with you at all times.
- ◆ Shop at one pharmacy to have all your prescriptions filled.
- ◆ Return all expired medications to your pharmacist.

## Assistive Devices

Devices such as canes, grab bars, handrails, hip protectors and walkers can really help prevent falls and reduce the risk of injuries. Individuals with balance and mobility problems are encouraged to use assistive devices for daily activities.

### Assistive devices can make your bathroom safer:

- ◆ Use a long rubber bath mat inside your tub.
- ◆ Install at least two grab bars in the tub area.

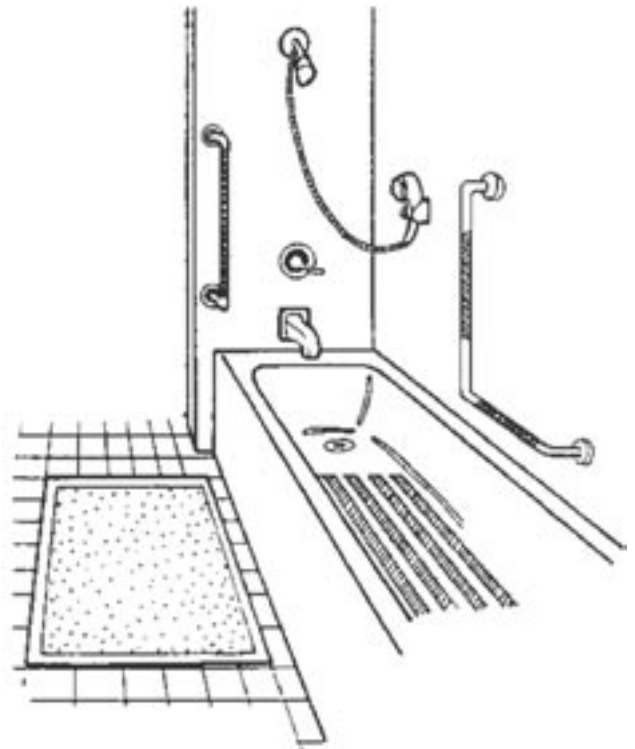

- ◆ If getting into or out of the tub is difficult, consider buying a bath seat and a hand held shower or getting help with bathing.
- ◆ If sitting on or getting up from the toilet is difficult, consider buying a raised toilet seat and/or installing a grab bar.

## Use a cane

### To make sure your cane is the correct height for you:

- ◆ Turn the cane upside down and put the handle on the floor.
- ◆ Stand with your arms at your sides.
- ◆ The tip of the cane should be at the level of your wrist.

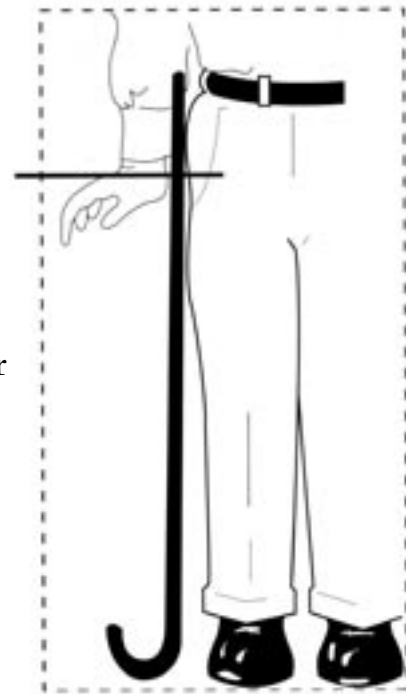

### To adjust a wood cane:

- ◆ Turn the cane upside down, mark the cane at the level of your wrist.
- ◆ Remove rubber tip.
- ◆ Cut the cane 1/2 inch shorter than where you marked it.
- ◆ Replace rubber tip.

### To adjust an aluminum cane:

- ◆ Most aluminum canes can be easily adjusted within an inch of the desired height.

Remember to replace worn rubber tips on your cane and do not forget to attach an ice pick in the winter.

### For healthy strong bones:

Eat calcium rich foods such as milk products, almonds, baked beans, salmon (with bones), dark green veggies, rhubarb. Ask your doctor about Vitamin D and calcium supplements.

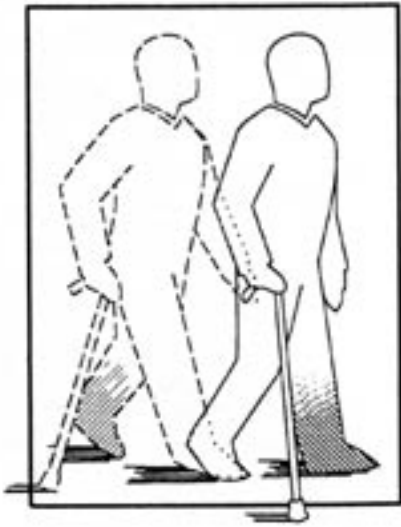

### Learn to use a cane correctly:

- ◆ Always hold your cane on your strongest side.
- ◆ If you have a “bad” leg (weak or painful) hold the cane opposite the “bad” leg.
- ◆ Always move the cane and the opposite leg together.
- ◆ To go up the stairs, take the first step up with your strong leg. Then, move the cane and the “bad” leg to the same step.
- ◆ To go down the stairs, take the first step down with the cane and the “bad” leg. Then, lower the strong leg to that same step.

### Wear hip protectors

A hip protector is a lightweight belt or pant with shields to guard the hips against fractures and give added confidence.



### Use a walker for safer travels:

- ◆ Adjust your walker to your height.
- ◆ Roll the walker forward as you take steps standing straight into the centre of the walker.

Learn to use the hand brakes correctly.

To sit on the seat of the walker:

- ◆ Lock firmly in place.
- ◆ Turn around slowly; transfer one hand to the opposite walker handle. Keep hands on both handles as you sit down.

When standing up from a chair or bed with your walker:

- ◆ Position walker in front of you and lock the brakes.
- ◆ Push up from the bed or chair; the walker could tip if you pull on it.
- ◆ Unlock brakes before you start walking.

To transfer to a chair with your walker:

- ◆ Walk to the chair and turn around using the walker.
- ◆ Back-up to the chair until the back of your legs touch the seat.
- ◆ Lock the brakes, reach for chair armrest for support and sit down.

Hardware stores, department stores, drug stores and specialty stores may have useful devices to help make daily activities easier and safer. (See “Hospital Equipment and Supplies” in the Yellow Pages.)

## **Hazards in and around your home**

Unsafe surroundings contribute to 30% of both indoor and outdoor falls. Poor lighting, unsafe footwear, and icy sidewalks are just a few of the environmental hazards that cause people to fall.

Baseline Data, Ottawa-Carleton Falls Research Project, 1994.

### **What to do:**

1. Identify unsafe areas inside and outside your home
2. Complete the checklist on the following pages.
  - ◆ Your risk of falling increases with the number of hazards identified with a “No” answer.
3. Start today to make changes to reduce the hazards in your home.
4. Report hazards outside your home to the proper authorities:
  - ◆ In an apartment building, store or restaurant, contact the owner or manager.
  - ◆ In a shopping mall, contact the mall authority.

## Check list for falls prevention in your home

<b>Throughout your home</b>	
	Floors are not slippery. Spills are wiped up promptly.
	Pathways are clear of extension cords and other objects.
	Rugs have no ripples or tears.
	Scatter mats are removed or securely taped to the floor.
	Low tables are removed from the middle of the living room.
	All furniture is sturdy.
	Chairs have armrests and are the correct, comfortable height.
	All light fixtures have a minimum of 60 watt bulbs. Good lighting is installed in and around the house.
	Entrance to every room has a light switch.
	Stepladders or step stools are never used.
	Items used every day are stored within easy reach.
	Exterior stairs are kept free of ice and snow. Sprinkle grit or non-clumping cat litter.
<b>Entrance</b>	
	Doors open easily.
	There is a sturdy seat with armrests.
	Mail is within easy reach.
	Exterior and interior lighting is good.
	Outside pathways are free of lawn furniture, hoses and other objects.

<b>Stairs (inside and outside)</b>	
	Stair edges are marked with contrasting colour.
	All steps are the same height and the same depth.
	Stairs are well lit with a light switch at the bottom and top of stairs.
	Stairs have a non-slip surface and are in good repair.
	Handrails are present on both sides of stairs.
	Handrail height feels comfortable when used for support.
	Handrails extend 12 inches beyond top and bottom steps.
	Hand wraps around two thirds of handrail.
	Stairs are free of clutter or any objects at all times.
<b>Bathroom</b>	
	Bathtub plug is easy to reach; and to use.
	Full-length rubber bathtub mat is used for every bath or shower.
	There are at least two grab bars in the tub area.
	Portable grab bars (on the side of the tub) do not move when used for support.
	Rug outside the bathtub has a rubber backing.
	<p>If you have problems getting into or out of the bathtub:</p> <ul style="list-style-type: none"> <li>◆ Use a bath seat.</li> <li>◆ Use a hand held shower.</li> <li>◆ Ask for help with bathing.</li> </ul>
	<p>If you have problems sitting on or getting up from the toilet:</p> <ul style="list-style-type: none"> <li>◆ Use raised toilet seat.</li> <li>◆ Use a grab bar conveniently located.</li> </ul>

Handout 1

<b>Bedroom</b>	
	A telephone is easily reached from the bed.
	A lamp and flash-light are easily reached from the bed.
	The bed is the correct height.
<b>Personal Habits</b>	
	I move slowly after lying or sitting to prevent dizziness; and sit on the side of the bed a few minutes before I stand.
	I do not hurry.
	I always wear well-fitted shoes or slippers with closed and low heels and non-slip soles.
	I do not use bath oil and I use liquid soap to avoid bending for soap bar.
	I do not wear long skirts, long house coats, or loose slacks that I might trip or step on.
	I turn on a night-light before I go to bed.
	I turn on a light when I get up at night.
	I avoid using a ladder or step-stool and ask for someone to help to reach high objects.
	Living alone, I use a Personal Emergency Response Calling Service or I buddy with a neighbour, family or friend for a daily phone call.

Adapted from “A Guide to Preventing Falls”, City of Ottawa

*Active Independent Aging was a joint venture between the University of Ottawa and the Public Health and Long-term Care Branch, City Of Ottawa. For more information please visit our website at: [www.falls-chutes.com](http://www.falls-chutes.com). Funding provided by Health Canada/ Veterans Affairs Canada Falls Prevention Initiative. The views expressed herein do not necessarily represent the official policies of Health Canada, Veterans Affairs Canada, the University of Ottawa and the Public Health and Long-term Care Branch, City Of Ottawa. The information in this handout is current as of 2004.*